

OPERATOR'S MANUAL

654CS VIBRATION METER AND MINI ANALYZER KIT

TABLE OF CONTENTS

	<u>PAGE</u>
IMPORTANT NOTICES	a
RECEIVING AND HANDLING	1
INTRODUCTION	1
DESCRIPTION	3
SPECIFICATIONS	7
OPTIONAL ACCESSORIES	8
TYPICAL APPLICATIONS	9
OPERATIONAL DETAILS	9
VIBRATION ANALYSIS	15
APPENDIX	
4071 Accelerometer Installation and Specifications	--

Vitec, Inc.
Cleveland, OH 44122
Phone: 216-464-4670 Fax: 216-464-5324



1st Important Notice

Because of the high sensitivity of this unit over a wide frequency range, (5 Hz to 10,000 Hz, 300 to 600,000 CPM) the following is highly recommended for all displacement (mils) readings.

1. Use the 20 or 200 mils range. The 2 mil range should only be used on finely balanced equipment, or in a laboratory environment.
2. Use the magnetic pickup clamp or the 1/4"-28 stud mount provision in bottom of pickup to mount the pickup on the machine being tested. Hand-held pickup readings taken with pencil probe may be erratic.

2nd Important Notice

This instrument is equipped with rechargeable nickel cadmium batteries.

CAUTION: Do not recharge batteries until "LO BATT" indication appears on the display.

1. You can use the instrument for approximately 2 hours after "LO BATT" appears on the display before readings become unacceptable.
2. If readings become unacceptable the instrument can be used with battery charger connected.
3. Do not use any other battery charger than the one which is supplied with your instrument.

RECEIVING AND HANDLINGPRODUCT WARRANTY

The Vitec Model 654 CS is warranted to be free from defects in material and workmanship for a period of one year from the date of shipment to the original user or 18 months from date of shipment by company to buyer, whichever period is shorter. Damage in shipment, abuse, and misuse, are not part of this warranty.

Claims of defects in this apparatus must be submitted to the company in writing in the above mentioned time period. The buyer shall be responsible for all transportation charges.

ACCEPTANCE

Vitec terms of sale are F.O.B. point of origin, freight prepaid. Thoroughly inspect this shipment before accepting from the transportation company. If any of the packaging is damaged or the quantity listed in the bill of lading or express receipt is short, do not accept until the freight or express agent makes an appropriate notation on your freight bill or express receipt. Request him to make an inspection. Claims for loss or damage in shipment may not be deducted from the Vitec invoice, nor may payment of the Vitec invoice be withheld awaiting adjustment of such claims since the carrier guarantees safe delivery.

If damage or loss has occurred to your shipment and the situation is urgent, contact the nearest Vitec District Office for assistance.

INTRODUCTION

This manual has been prepared to instruct operating personnel in the proper operation, application, and maintenance of the Vitec Model 654 CS Mini-Analyzer (figure 1). In order to obtain maximum usage from the instrument, the contents of this manual should be studied thoroughly.

The Model 654 CS Mini-Analyzer is simple to use, and should present no problems to the operator. Any repairs or service should be performed only by qualified personnel or by a Vitec service representative.

MODEL 654 CS MINI ANALYZER

Figure 1

DESCRIPTIONGENERAL

The Vitec Model 654 CS Mini-Analyzer (fig. 1) is a portable instrument intended for general purpose vibration measurements and analysis. The Model 654 CS is packaged in a clipboard which allows vibration readings to be recorded much easier than was possible before. The unit is ideally suited for performing in-plant product testing, machinery start-up and checkout, and in preventive maintenance programs.

The Model 654 CS responds to vibration in units of displacement (mils), velocity (inches/second), and acceleration (G's), all of which may be fed through the tunable filter portion of the instrument for analytical evaluation. The meter used with its associated high output accelerometer is capable of making accurate vibration measurements over a frequency range of 5 Hz to 1500 Hz at $\pm 5\%$ tolerance, 1500 Hz to 3500 Hz at 10% tolerance, and is usable to 5000 Hz.

The basic controls necessary for operation of the Model 654 CS are located on the right hand side of the instrument.

The Model 654 CS is powered by a Ni-Cad battery pack assembly.

VIBRATION LEVEL READOUT (fig. 2)

The vibration level is easily read on the large LCD (Liquid Crystal Display) on the face of the meter. The meter will read out directly in mils, inches/sec., or G's depending upon the setting of the mode switch. The direct readout display eliminates the need for multiple scales or scale multipliers. Should the vibration level be higher than the range selected, the last three digits of the display will be blanked out to indicate an "over ranged" condition.

The LCD display also provides a "Lo Batt" display in the upper left hand corner of the display when the batteries are low and should be recharged. Readings can, however, be taken for approximately 2 hours after the "Lo Batt" indication first appears. Use of the unit beyond this period may result in faulty or incorrect readings.

IMPORTANT - As with all Ni-Cad batteries, recharging before required will decrease the duration which the unit can hold a charge. Therefore care should be taken to recharge only when indicated by "LOW BATT" light on LCD.

VIBRATION FREQUENCY READOUT (fig. 1)

The vibration frequency (CPM) of the tunable filter is displayed on the mechanical display used to set the filter. (Dial setting x 10 = frequency in "LO" filter position, Dial setting x 100 = frequency in "HI" filter position.)

DESCRIPTION (Continued)FILTER RANGE SELECTION (fig. 1)

This switch (marked "Filter") is used to select low, high, or non-filtered operation, as explained above. In the "OUT" position, readings are broad band, limited only by the frequency response characteristics of the instrument and transducer.

MODE SWITCH (fig. 2)

The Mode Switch selects the mode of vibration to be measured. The vibration can be measured in acceleration, velocity, or displacement (refer to application section). Merely turn the selector switch to the mode desired.

The "OFF" position of this switch shuts off power to the instrument (the instrument must be in this position when not being used to prevent battery drain).

RANGE SWITCH (fig. 2)

The range switch selects the full scale range for the vibration mode being measured, and causes the decimal point to be located on the display accordingly.

NOTE: If no prior readings or typical levels are available it is advisable to start in the G's mode, 200 range, and select lower ranges as needed until the meter reading is .1 or more. Use of this procedure will help to eliminate over-range errors.

"INPUT SIGNAL" JACK

The input signal jack receives a 1/4" phone plug (heavy duty), which is used to feed the transducer signal into the system.

NOTE: In order to assure data integrity, the plug must be fully inserted.

DESCRIPTION (Continued)OUTPUT JACK (fig. 2)

The Model 654 CS has a BNC type connector on the side which provides an A.C. Signal representative of the actual A.C. vibration signal. The calibrated output is representative of the actual waveform seen by the transducer.

NOTE: The signal output is affected by the setting of the tunable filter, when used, and the range mode controls but not by the damping switch setting (i.e., in the G's mode, the output is proportional to acceleration, in velocity mode the output is proportional to velocity, etc.).

VIBRATION TRANSDUCER (Pickup)

The transducer, (pickup), converts the mechanical vibration being measured into an electrical signal which is transmitted to the vibration meter. The high sensitivity accelerometer used with the Model 654 CS provides very accurate measurements over a wide range of frequency measurements, (300 to 60,000 CPM).

NOTE: Specially calibrated Model 654 CS meters are available to measure frequencies as low as 120 CPM.

The 1/4"-28 x 1/4" deep tapped hole in the bottom of the transducer is provided for installation purposes. To assure accurate and repeatable readings, a 1/4"-28 stud (i.e. a 1/4"-28 x 1/2" setscrew, available from local suppliers) should be installed in the bearing cap or other monitoring site, so that the transducer may be quickly and rapidly installed when measurements are to be taken.

The pencil probe or magnetic mount supplied with the instrument may be used for non-precision or survey type measurements. A vice-grip type clamp is also available as an optional accessory for similar applications.

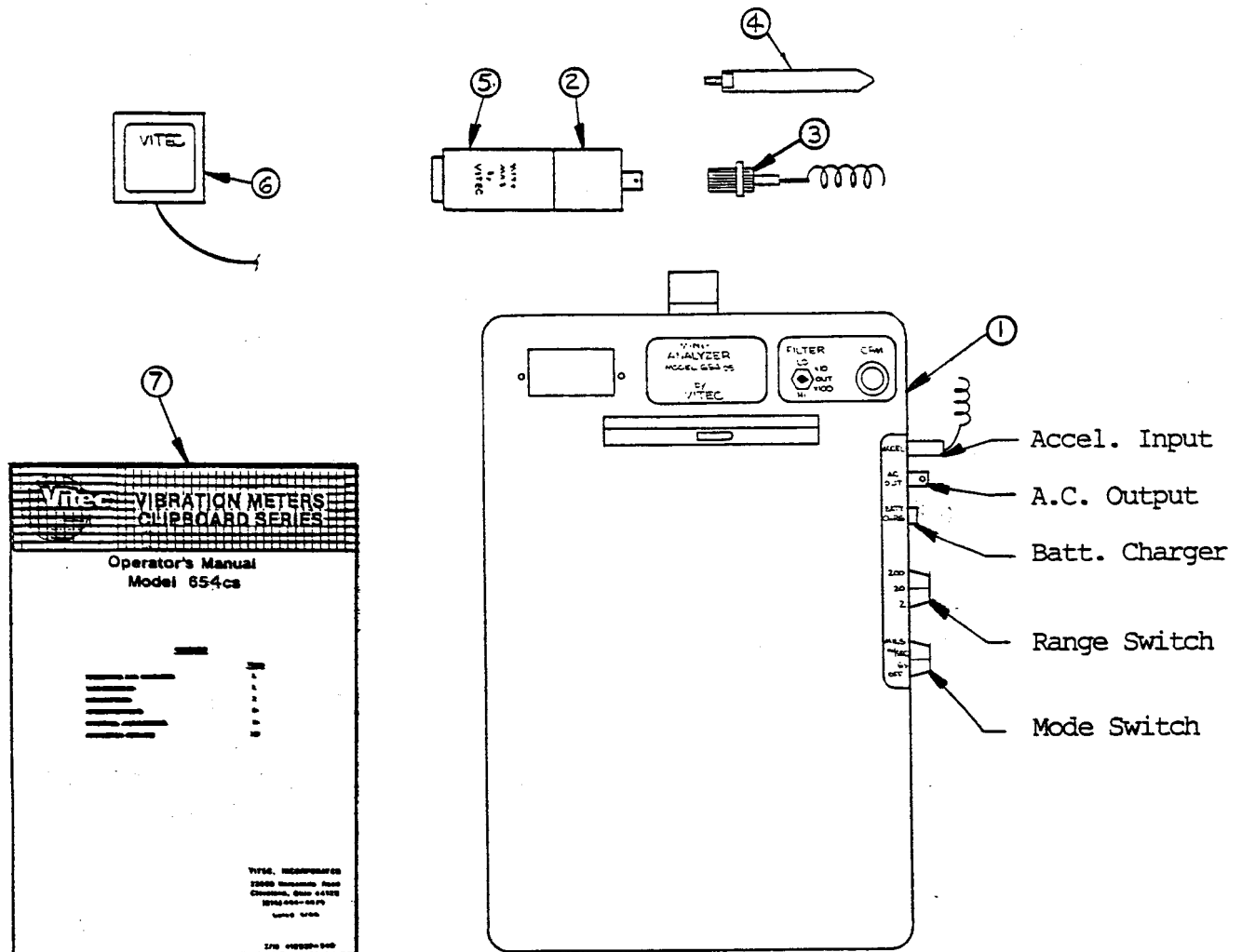

FIGURE 2

YOUR VITEC MODEL 654 CS VIBRATION METER KIT INCLUDES:

- 1.) Model 654 CS Vibration Meter
- 2.) Accelerometer Pickup, Model 4071
- 3.) Coiled Pickup Cable
- 4.) Pencil Probe
- 5.) Mity Mag
- 6.) Battery Charger
- 7.) Instruction Manual

SPECIFICATIONS

Modes:	Displacement (Mils), velocity (in/sec), acceleration (G's)
Ranges:	Amplitude 0-2, 0-20, 0-200 Frequency 10-10,000 CPM, 10-100,000 CPM, Manual Tune, Bandpass
Filter Bandwidth:	Q = 17
Accuracy:	± 5% 5 Hz to 2,000 Hz usable to 5K Hz
Display:	Amplitude 3 1/2 Digit LCD Display Frequency, 3 Digit Mechanical Display
Meters:	Large easy to read LCD digital display
Pickup:	Piezoelectric accelerometer with Coiled Cable.
Batteries:	Ni-Cad Rechargeable Battery Pack
Battery Life:	Approximately 40 Hrs. "LO BATT" appears in LCD display when battery level gets low.
A.C. Output:	Side mounted BNC Output jack provides a calibrated A.C. signal proportional to mode and range selected.
Operating Temp:	33°F to 150°F
Weight:	3 Lbs.

OPTIONAL ACCESSORIES

Several accessories are available to make the Model 654 CS Meter easier to use: They are:

UNIVERSAL VISE GRIP CLAMP (fig.3) allows for direct clamping of accelerometer to surface being measured. Ideal for clamping pickup to non-magnetic or irregular surfaces. Ask for P/N 602885-11RB.

VIBRATION HISTORY CHART (fig. 3) is a preprinted form for recording vibration levels for predictive maintenance. Ask for form 412512-110.

UNIVERSAL VICE GRIP CLAMP

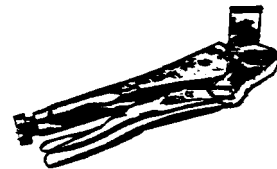

VIBRATION HISTORY CHART

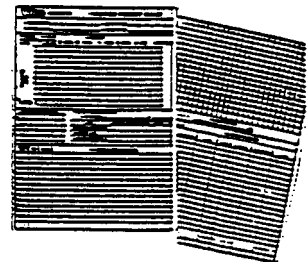

Figure 3



TYPICAL APPLICATIONS

1. Preventive Maintenance - Probably the most useful application of this instrument. When used to make periodic measurements, data comparisons can be made which will detect an increasing trend in vibration. This further investigation can be made to determine the exact nature of the problem area. (A useful tool for complete analysis and/or dynamic balance is the Vitec Balance Analyzer.)
2. Field Service - With a few simple measurements, a field service engineer can determine the amount of vibration. This can avoid costly shut-down to inspect parts needlessly.
3. Incoming Inspection - Vibration tolerances are often included in specifications for purchased parts to prevent excess vibration in final products. The Model 654 CS is ideally suited for receiving or assembly line inspection.
4. Final Assembly Test - Vibration tests on finished products can be made prior to shipment to assure compliance with production quality standards.

OPERATIONAL DETAILS

GENERAL

One of the primary uses for the Model 654 CS Mini-Analyzer is to measure machinery vibration over a period of time. An increasing trend in the amount of vibration detected is a good indication that the machine will soon need repairs because of bearing wear, loose or worn internal parts, or a general condition of unbalance. Early scheduling of such repairs will often result in avoiding costly, non-scheduled down-time caused by failure of a defective component.

If vibration exceeds allowable limits the machine should definitely be inspected for the cause of trouble.

The best point on a machine to measure vibration is on the bearing housing. If bearing housings are not readily accessible, place the pickup on a nearby associated support or structure. See Figure 4 examples.

Keep in mind, however, that excessive vibration detected at a bearing housing may not mean that the cause is a faulty bearing. For example, a loose rotor component in a motor or generator can result in vibration that would be transmitted along the rotor shaft to the bearing housing.

VIBRATION TOLERANCES

The allowable limit of vibration which can be tolerated in a machine depends on many factors, including:

1. The product desired from the machine. (grinding and finishing)
2. Stiffness of the bearing supports and the base.
3. Alignment of the couplings and bearings.
4. Operating speed as related to resonance and critical speed.
5. Transmitted vibration from other sources.

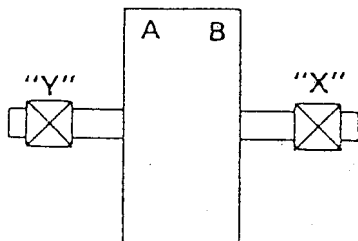

SUSPENDED ROTOR

Readings taken for Plane "A" at Bearing "Y".
Readings taken for Plane "B" at Bearing "X".

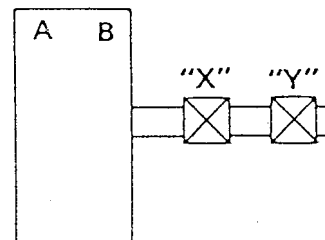

OVERHUNG ROTOR

Readings taken for Plane "B" at Bearing "X".
Readings taken for Plane "A" at Bearing "Y".

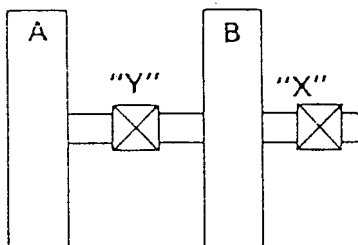

COMBINATION OVERHUNG SUSPENDED ROTOR

Readings taken for Plane "A" at Bearing "Y".
Readings taken for Plane "B" at Bearing "X".

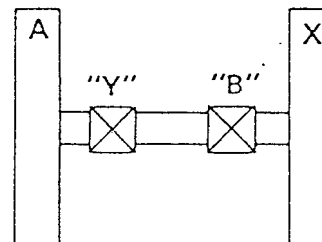

DOUBLE OVERHUNG ROTOR

Readings taken for Plane "A" at Bearing "Y".
Readings taken for Plane "B" at Bearing "X".

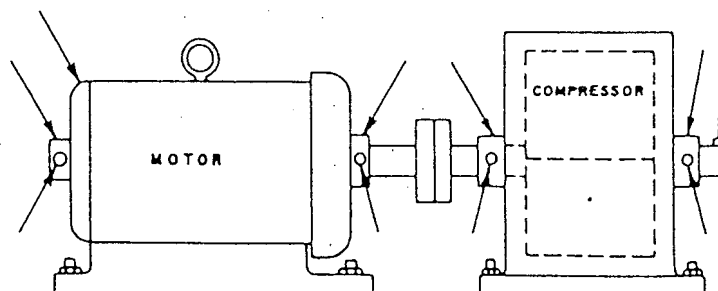

Figure 4. Points for Measuring Vibration (Example).



Machine products tested satisfactorily for allowable vibration limits during manufacture may offer different results when the same tests are performed under actual field installation and operating conditions. For this reason, it is sometimes difficult for a manufacturer to supply standard allowable limits of vibrations for each item delivered. However, tentative guides can be set up for certain types of machinery listing vibration tolerances as a standard for comparison.

Effective guidelines for your particular applications can only be established through your own experience.

TAKING MEASUREMENTS (Filter in "OUT" Position)

Hold the pickup probe against the machine...preferably the bearing housings. Take readings with the pickup in both vertical and horizontal plane with respect to the machine. An axial measurement is also recommended if obtainable. Record readings for future reference.

Be sure to apply enough pressure to the pickup to maintain solid contact with the machine and to prevent the probe from chattering. The pickup should be held perpendicular to the rotating shaft of the machine. Be very careful to take successive or future readings for trending or comparison at the same location on the machine. Readings taken at different points on the machine being measured cannot be used for measuring changes in vibration levels.

NOTE: Although the pencil probe is most useful for spot-checking and diagnostic survey applications, it is generally more advisable to use a mounting stud, for purposes of long term history and analytical work.

MEASURING DISPLACEMENT (Mils)

Measuring vibration in a peak-to-peak displacement mode results in detection of actual physical displacement or movement of the surface to which the pickup is attached. The vibration is measured in mils pk. to pk. (1 mil = .001").

MEASURING VELOCITY (In/Sec.)

Measuring vibration in the peak velocity mode results in detection of the rate of change of displacement. This vibration is measured in terms of peak velocity or IN/SEC peak. Refer to Figure 4a example.

Velocity is a function of both displacement and frequency, and therefore will have additional sensitivity to higher frequency vibration. For example, a 1 MIL displacement will have the same vibration meter reading at 1000 cpm as at 10,000 cpm. The velocity for 1 MIL at 100 cpm is .052 IN/SEC, while at 10,000 cpm, the velocity is .52 IN/SEC, or 10 times larger. (The latter being a truer indication of force.)

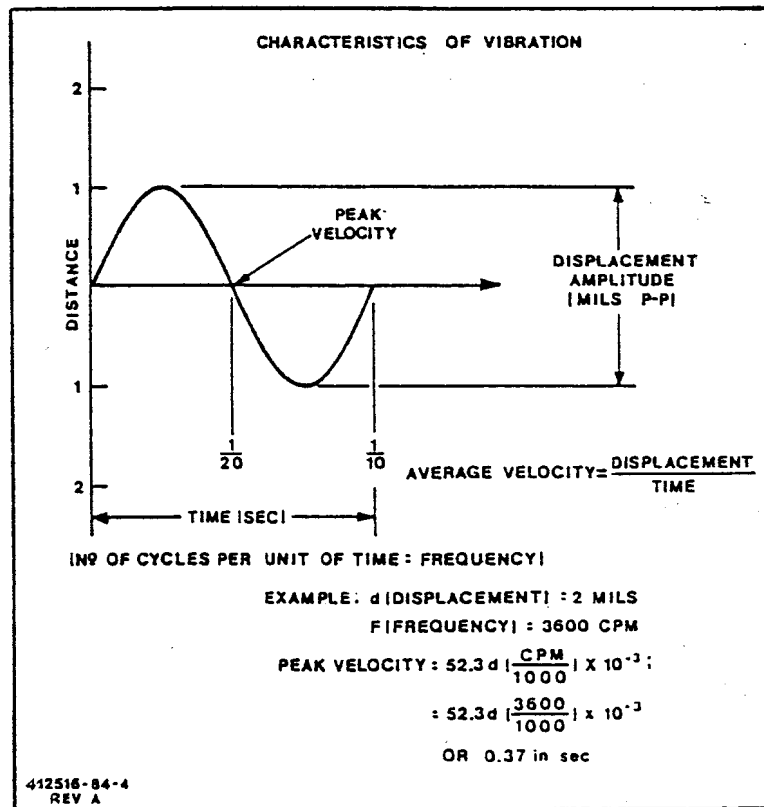

Figure 4a



MEASURING ACCELERATION (G's)

Measuring vibration in the peak acceleration mode results in detection of the rate of change of velocity, or how fast a surface is accelerating with respect to a fixed reference. The acceleration is measured in terms of peak acceleration or "G's". One G = 386 Inches/Second².

The acceleration mode of measurement is especially effective in detecting small displacement, high frequency vibration such as would be produced by antifriction bearings, gears, etc. For example--- a very small displacement of .01 MILS (.00001") occurring at 60,000 cpm produces an acceleration signal of .51 G's. Obviously a .0001" signal is hard to measure, but a .51 G signal would be easy to measure.

TUNABLE FILTER ANALYSIS

Any series of data taken should include measurements taken as indicated above, which are helpful in limiting the number of readings needed. In the filter "Out" position, total vibration level is read without regard for frequency.

The Mini-Analyzer may then be set to the "Hi" or "Lo" filter position, and readings taken at the operating speed of the device under test (CPM=RPM). If these readings are essentially the same as the baseline readings at other frequencies will not be appreciably high.

If there is a significant difference between the baseline data and the data taken at operating speed, then further data should be taken at twice operating speed, three times operating speed, etc., until the readings add up to approximately the level of the baseline data.

NOTE: The magnitudes and frequency of each data set should be recorded; the frequency says more about where the problem is, the amplitude say more about how "bad" the problem is.



CIRCUIT DESCRIPTION

The Model 654 CS uses four amplifier stages. A6, in conjunction with the range switch, determines the operating range of the instrument. A5 is an A.C. integrator circuit, which integrates the acceleration signal to obtain velocity. A3 is also an A.C. integrator, which integrates the velocity signal to obtain displacement. A 5 Hz., 12 db octave high pass filter A4 precedes the displacement integrator to reduce the noise when measuring displacement. Amplifier A1B is a voltage buffer providing low impedance A.C. output at the BNC.

U1 is a true RMS to D.C. converter which supplies the input signal to the A/D converter, U1 (located on the display board). U1 is an A/D converter and LCD driver chip which drives LCD1 (also located on the display board).

U3 in conjunction with the range switch establishes the decimal point for the LCD display.

U2 is a low voltage sensing circuit which automatically senses the low voltage condition of the batteries and displays a "LO BATT" condition on the LCD. Typical battery life is approximately 40 hours.

CHECKING CALIBRATION

I. ACCELEROMETER

The calibration of the accelerometer can only be verified on a shaker table. Please contact factory.

II. MODEL 654 CS

The calibration of the M654 CS can be checked by removing the accelerometer from the cable and applying a 70.7 MV RMS signal @ 100 Hz to Pin "C" of the cable plug, using Pin "A" for signal common. Turn Mode switch to "G's", reading should be 1G. Turn Mode switch to "IN/SEC", reading should be .614 IN/SEC. Turn Mode switch to "MILS", reading should be 1.96 MILS. If your instrument does not give you these readings, consult factory.

VIBRATION ANALYSIS

In Chapter 3, we stated that a vibration analyzer allows you to determine the cause of a vibration problem by supplying you with both amplitude and frequency data. Thus, vibration analysis breaks the overall vibration into its frequency components, and by knowing what frequencies are generated by various mechanical problems - the cause of vibration can be determined.

A very simple example will serve to illustrate this concept. An automobile is vibrating as a result of two problems: 1. The front tire has a "bubble" that causes a vibration very time it hits the pavement, and 2. the kids are jumping up and down in the back seat. A vibration meter would display the overall combined vibration of the two problems. The vibration analyzer, on the other hand, can separate the two problems into their frequency components. It could separate the kids jumping at 5 cycles per minute from the tire problem which may be happening at 50 cycles per minute. It could also tell you how much vibration is happening at each frequency, which obviously allows you to determine how much vibration is caused by each problem, and allow you to take corrective action. Figure 21 is a graphic representation of these two problems. As you can see, the vertical bars plotted on the axes represent both the amplitude and frequency of the vibrations that exist. In this example we have 2 mils vibration at 5 CPM and 3 mils of vibration at 50 CPM. This type of plot is commonly referred to as a "vibration signature" or "signature analysis".

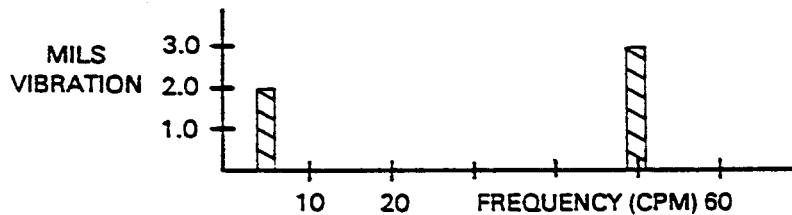

Figure 21
A simple vibration signature.

The same basic principles apply to machinery vibration analysis. Various mechanical problems will create different frequencies and amplitudes of vibration. An analysis of the vibration signature will allow you to determine the probable cause of vibration.

Again - none of the data listed is "magic" - all vibrations can be analyzed by determining "what mechanically in this particular machine can cause a vibration at this frequency and amplitude". A good understanding of the machine to be analyzed is essential to proper vibration analysis.

A strobe light should be used for visual examination of the machine to be analyzed. The number of reference marks that are revealed under strobe illumination should be recorded. These data may play an important role in correlating findings.

To avoid errors, all filter-in and filter-out readings should be taken consecutively at each key point and recorded.

The following pages contain a reference chart listing common vibration problems, followed by a descriptive section which explains why a particular vibration problem exhibits the vibration characteristics it does.



REFERENCE CHART - VIBRATION SOURCES

PROBABLE CAUSE	FREQUENCY relative to machine rpm	STROBE "PICTURE"	AMPLITUDE	NOTES
Unbalance	Rpm × 1	One - Steady	Radial - steady	Most common cause of vibration
Bent Shaft	Rpm × 1 (or × 2)	1, 2, or 3	Axial - high	Strobe picture depends on machine -usually unsteady
Anti-friction Bearings	Rpm × 20 to × 50 (or more)	Unstable	Radial - low	Use acceleration Mode
Sleeve Bearings	RPM × 1	One - Steady	Shaft = Bearing Rdgs.	Compare shaft to bearing readings
Faulty Belts	Rpm × 1 to Rpm × 5 (Belt Rpm × 2)	See "Notes" Column	Radial - Unsteady	Freeze belts with strobe and observe
Oil Whip	Less than machine rpm	Unstable	Radial - Unsteady sometimes severe	Frequency is near ½ rpm (commonly 42% to 48% × Rpm)
Gears	High (related to number of gear teeth)	--	Radial -- low	Use velocity or acceleration mode
Looseness	Rpm × 2	2	Proportional to looseness	Frequently coupled with misalignment
Foundation Failure	Unsteady	Unstable	Erratic	Shows up when balancing
Resonance	Specific "criticals"	1	High	Increased levels at critical speeds
Beat Frequency	Periodically varying	--	Pulsating	Caused by close rpm machines
Misalignment:				
Parallel	Rpm × 1, × 2	1, 2 or 3	Radial	Axial amplitude = .7 or higher of vertical or horizontal
Angular	Rpm × 1, × 2	1, 2 or 3	Axial - high	
Electrically Induced:				
Note: All electrical problems can be confirmed by cutting power to machine - problems should disappear immediately.				
Loose Stator Laminations	High frequency (over 60K cpm)		Radial high - steady	
Stator Problems (shorts)	2 × line F		Radial	
Blade/Vane Pass	Number of blades/ vanes × Rpm		Radial - fluctuating	Look for radial vibration in direction of discharge piping
Cavitation	Random		Fluctuating	Can be up to 2000 Hz

CHARACTERISTICS OF COMMON VIBRATION CONDITIONS

(A Brief Description of Signature Origin)

UNBALANCE (1 × rpm)

Unbalance is the most common cause of vibration. It occurs when the center of mass of an object is not also its center of rotation. The apparent presence of a "heavy spot" causes forces to be applied which result in vibration. Unbalance produces a vibration reading whose amplitude is directly proportional to the amount of the unbalance, and whose frequency is the same as the running speed of the machine being measured.

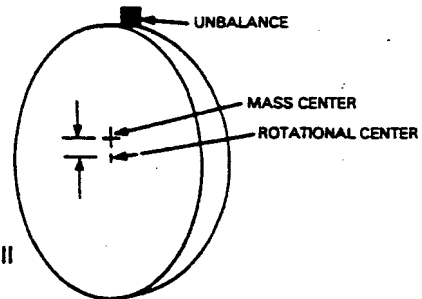

For example, an 1800 rpm motor which is unbalanced will have vibrations at 1800 cpm (30 cycles per second) and the amount of vibration will be proportional to the amount of unbalance.

BENT SHAFT (1 × rpm — sometimes 2 × rpm)

In case of a bent shaft, a high axial vibration level at a frequency of single and sometimes double shaft rpm will be noted. The figure shows the simultaneous and opposite axial deflection of the bearing housing. By observing the axial vibration at bearing A and bearing B, with the pickup held in the same direction on both bearings, the phase indication will be that of a static pair condition (reference mark at the same position for both bearings).

In the illustration, note that for every rotation of the shaft a vertical impulse on the out-board and in-board end of each bearing will occur. This results in two impulses of vibration for each rotation of the shaft. If the bent shaft condition occurs as deflection, or deformation, at operating speeds, it can in many cases be corrected by adding balance weights at the center of the shaft. This will tend to straighten the shaft and the mass center line will then coincide with the rotation center line. Normal two-plane balancing should be followed.

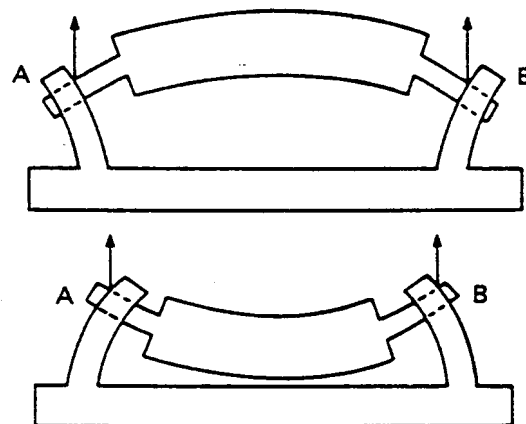

BENT SHAFT (Continued)

If shaft flutter, due to operating speed, is occurring and if the condition has been corrected by balancing, care must be taken to insure that changes in speed will not result in additional flutter of the rotor shaft.

If the bent shaft occurs due to actual physical deformation of the shaft, independent of rotation, the addition of balancing weight will have little effect.

The disproportionately large balance weight required to show any appreciable change in vibration level will show that a condition, other than mass displacement versus rotational centers, exists.

BEARINGS ANTI-FRICTION (Many x rpm)

In many cases, manufacturers balance the part by rotating it on the shaft, rather than in the bearing on which it will be finally assembled. If the rotational center of the anti-friction bearings in a race is not coincident with the physical center of the outer races, a difference in the mass center and rotational center of the shaft will occur. This obliterates any prior balance performed. If bearing replacement, after original machinery installation, does not take this factor into consideration, an unbalanced condition may occur.

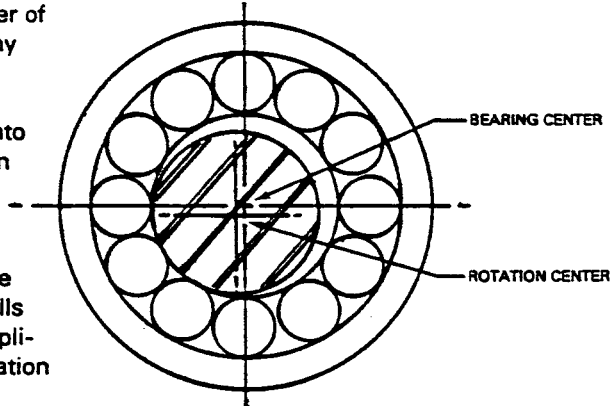

In the case of anti-friction bearings, the scoring or brinnelling of the balls or rolls will produce a high frequency, low amplitude vibration. It is best to use acceleration or velocity readings to detect bad anti-friction bearings. (A high frequency but low displacement signal has a high velocity, being a product of frequency and displacement, and higher acceleration being a product of the displacement times frequency signal squared.)

Verification of poor bearing performance is made by shutting off the machine and observing that the high bearing frequency remains as a unit reduces in speed. This high frequency signal will normally be retained until the machine comes to rest. The frequency indication is usually from 5 to 20 times the primary frequency of the part contained by the bearings.

BEARINGS, SLEEVE (1 x rpm)

Excessive clearance in sleeve bearings can normally be determined by comparing the vibration level reading on the bearing housing using an accelerometer or velocity pickup, as close to the bearing as possible, and the vibration level of the shaft itself using a non-contact probe. Note: the pickups must be in the same plane and direction when taking both readings.

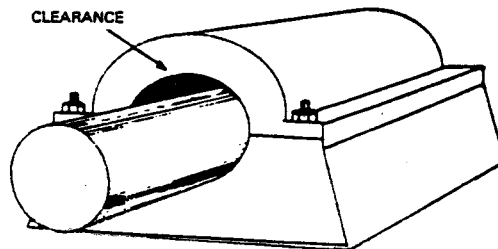

Sleeve bearings may also exhibit a condition known as "oil whip." This is discussed later.

MISALIGNMENT (2 × rpm)

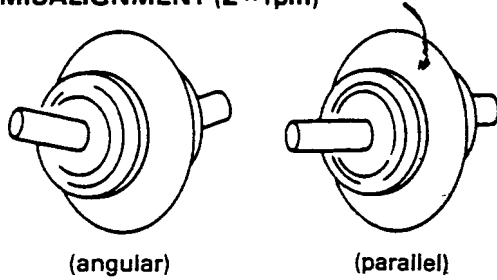

Misalignment of couplings and bearings results in a high axial vibration reading. This may be as much as 1.5 times the vertical or horizontal readings. This condition generally occurs at 2 times the running speed of the machine, although it may also occur at one (or even 3) times the running or primary frequency.

FAULTY V-BELTS (1—5 × rpm)

Faulty drive belts exhibit an unstable amplitude reading with a frequency of from one to five times the rotating speed of the machine. To determine if belts are bad, investigate under strobe light, freezing the belts for visual inspection. Relative slippage of one belt among several will usually be seen.

Vibration readings will be unsteady. This is caused by different sheave diameters, each with different unbalanced conditions, running at different speeds. Also, high and low points on each sheave will affect the running belt at varying times during rotation -- sometimes adding, sometimes subtracting. A vibration condition caused by faulty belts can best be corrected by installing perfectly matched sets of belts and assuring that high-quality sheaves are used.

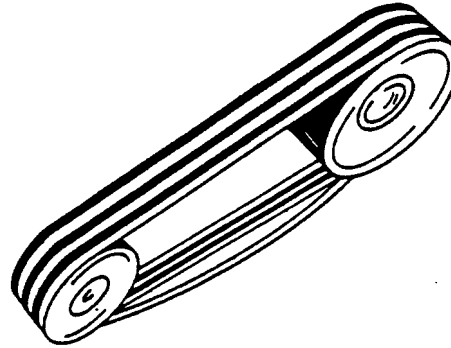

OIL WHIP (lower than shaft rpm)

A condition known as "oil whip" may occur in lightly loaded sleeve bearings. This instability is reflected by vibration frequency near, but always lower than one half, the actual shaft speed.

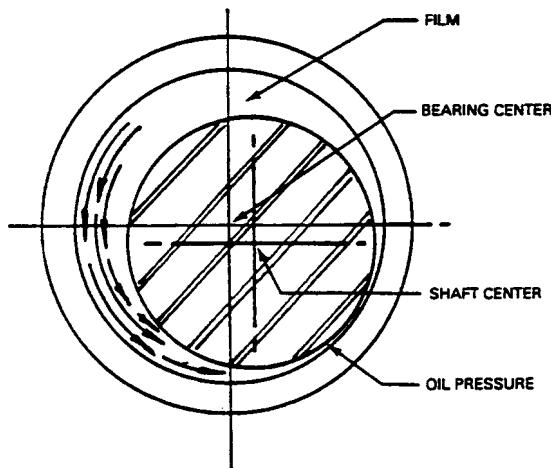

Correction of "oil whip" can be made by changing the bearing clearances, changing the positions of the oil groove, increasing the shaft loading, or changing the oil characteristics, such as viscosity.

A word of warning! Increased vibrations caused by "oil whip" or apparent "oil whip" may indicate a problem so severe as to warrant immediate correction or machine shutdown. Such an example would be if the lubrication system has failed completely to deliver lubricant to the sleeve bearing.

GEAR NOISE (Number of gear teeth \times rpm)

Gear noise or faulty gears produce a low-displacement high-frequency signal which generally has some integral relationship to the number of gear teeth: As in the case of detecting bad anti-friction bearings, use the velocity or acceleration mode of measurement. These vibration measurements will provide a better indication than displacement of the gear condition, since displacement, particularly on the gear cases, is likely to be quite low.

In a multiple stage gear set, the pickup probe should be placed on the bearing housing holding the problem gear and shaft.

LOOSENESS (2 \times rpm)

Mechanical looseness, coupled with misalignment of couplings or bearings, generally occurs at twice the machine rpm. Its amplitude is normally dependent on the amount of looseness and the design of the machine.

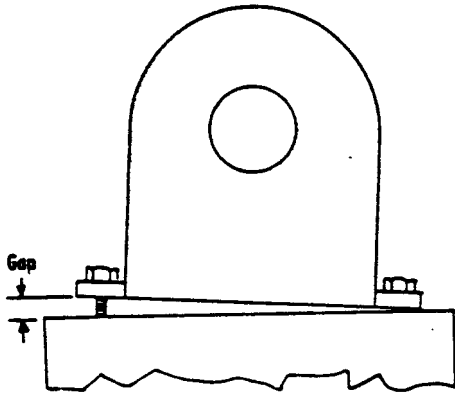

Unbalanced rotational forces (no system is in perfect balance) and changing torque loads, result in impacting of the base twice for each revolution. Excessive bearing clearance will produce the same results. Essentially, looseness allows more vibration to occur than what would otherwise be expected. This is particularly true in anti-friction bearings where small amounts of unbalance result in large vibrations at first and second harmonics of shaft speed. In most situations, this vibration will significantly reduce when the unbalanced force or misalignment is corrected.

FOUNDATION FAILURE (unsteady)

This condition can be determined by erratic changes in vibration amplitude and phase, occurring while conducting in-place balancing. This situation normally does not occur except in high-speed, heavy-mass equipment.

RESONANCE

Each part of a machine, as well as the machine itself, has a resonant frequency. Just as a tuning fork may be excited by a shock, small vibration or shock impulses may be synchronized with the resonant frequency of a machine, resulting in a high vibration level at critical machine operating speeds, tapering off if the speed is increased or decreased. The resonant frequency of a machine may be raised by increasing its stiffness, or lowered by increasing its mass.

VIBRATION ANALYSIS (Continued)

Under no conditions should a machine be operated in a resonant condition. When "criticals" are known to exist in the range of machine operating speeds, it is important that the machine pass through these points as quickly as possible.

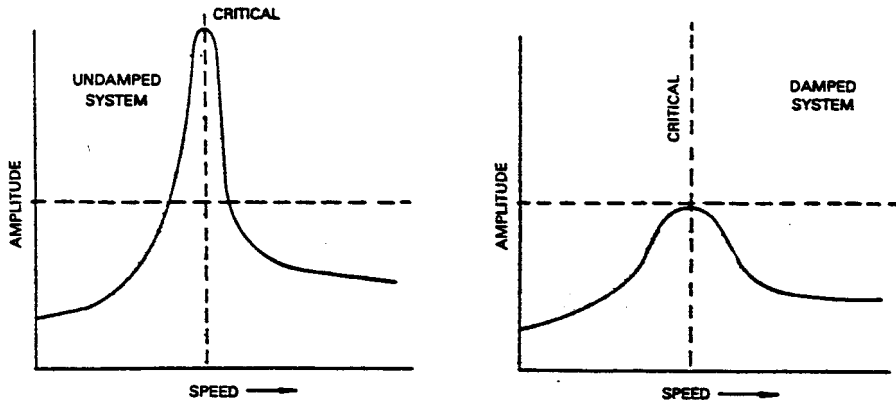

BEAT FREQUENCY (periodic fluctuation)

A periodic rise and fall in the vibration level occurs when two frequencies are close to each other. This condition (beat frequency) is a result of the periodic "in phase" and "out of phase" condition of the vibrations. Beat frequencies are often found in multiple belt assemblies, as a result of the slippage in the belts. Also, when motors of nearly identical speed are mounted on a common base, a small difference in their speeds can cause vibrations to come in and out of step. A beat frequency condition can be eliminated by reducing the level of vibration of one of the sources to the point where it will not materially add or detract from the other source. The figure here shows high and low levels of vibration resulting when two vibrations of the same level are close to the same frequency.

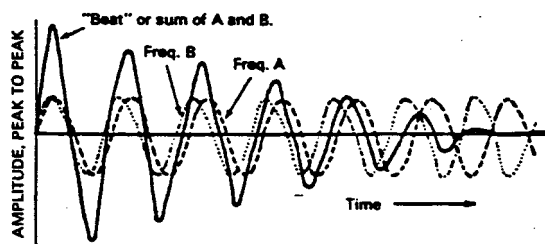

The presence of a beat frequency indicates a need to locate the secondary vibration source and to keep it under surveillance. Increased vibration levels from the unknown source, even though small, may cause severe problems in the primary machine when vibrations are "additive." Strobe lamps are useful in detecting the unknown source.

APPENDIX

4071 ACCELEROMETER INSTALLATION AND SPECIFICATIONS

APPLICATION

The 4071 Accelerometer is a high quality transducer used for general purpose machine vibration measurement. It has a 100 mV/G output that can be used with cable runs of up to 1,000 feet, and is suitable for use in temperatures up to 180°F.

INSTALLATION, ELECTRICAL

Cable Type: Use high quality, twisted, shielded cable between the transducer terminals and monitor terminals. Use of Vitec supplied cable assemblies is recommended.

Cable Length: Transducer to monitor cable length should not exceed 1,000 ft.

Cable Splicing: If cable splices are made, complete shielding must be maintained.

Cable Routing: Proper cable routing is required to avoid false signals being introduced into the measuring device (monitor). Avoid running accelerometer wires adjacent to, or parallel to, AC power lines. Where possible, provide a separate, grounded conduit to enclose the accelerometer cable. Route cable away from radio transmission equipment, motors, generators, and transformers. Avoid running cable through areas prone to ESD (Electro Static Discharge) or EMI (Electromagnetic Interference).

Cable Grounding: Connect the cable shield to a good, earth ground connection, at one end only (preferably at the monitor end of the cable). Vitec monitors provide this connection as a terminal block connection point.

INSTALLATION, MECHANICAL

Location: Mount on, or as close as possible to, the bearing being monitored. Preferable mounting location is on the bearing cap.

Direction: The accelerometer is only sensitive to vibrations that are occurring in the direction of the transducer's axis (the imaginary line running through the center of the connector and the mounting stud). Therefore, mount the transducer in a direction that will sense the vibrations to be measured.

Operating Position: The 4071 Accelerometer can be mounted in any position, there are no mounting position restrictions.

Surface Preparation: The mounting surface must be flat and smooth. For best results, mounting surface should be flat to within 0.001 in TIR (Total Indicated Runout) over the full base dimension of the transducer, with a minimum 63 μ in finish.

Stud Mounting: If stud mounting is used, drill and tap the mounting point for a 1/4-28 UNF stud, with a minimum thread depth of 3/8 in.

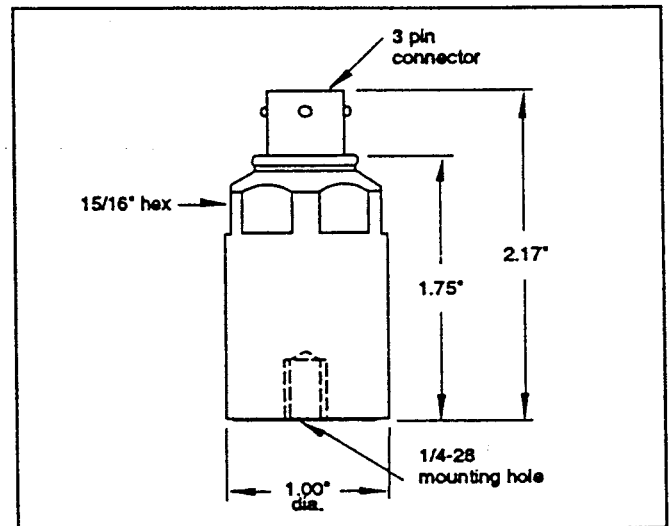

SPECIFICATIONS

Dynamic:	
Output, mV/G, +/- 5%	100
Dynamic Range, Gs, peak	0.01 to 60.0
Frequency Response, Hz, +/- 5%	2.1 to 3,500
First Mounted Resonant Frequency, KHz	≥ 7
Transverse Axis Sensitivity, % maximum	5
Shock Level, Gs maximum, peak	5,000

NOTE: When this transducer is used with either a 653 Vibration Meter and Bearing Tester or 654 Vibration Meter and Mini Analyzer, the frequency response range is limited to 5.0 to 1,000 Hz by the 653 and 654 electronics.

Electrical:	
Power Requirements, volts DC	8 to 30
Current Draw, mA	1.0 to 20
Connections (Connector): Pin A Pin B Pin C	0 Volts + Volts Signal

Environmental:	
Temperature Range, °F	-58 to 180
Humidity Limit, % relative	100

Physical:	
Vitec Part No.:	412790-39A
Weight, oz.	3.4
Case Material	Stainless Steel
Dimensions: Height, inches Body Diameter, inches Center Mounting Hole Wrench Flats, inches, at top	2.18 1.00 1/4-28 UNF x 3/8 in Deep 15/16
Mating Cable Assembly	Varies with application, contact factory

Vitec, Inc.
Cleveland, OH 44122
Phone: 216-464-4670
Fax: 216-464-5324